



# SCHEDA TECNICA PRODOTTO

## PF-3052 - **FOOD**

### PRODOTTI CONSUMABILI



### COLORI DISPONIBILI



## DATI TECNICI

- **Codice:** PF-3052
- **Descrizione:** distributore con additivo antibatterico di bicchierini in plastica Ø 5.5 cm con riduttore
- **Capacità:** ~ 70 bicchieri
- **Tipo di funzionamento:** manuale
- **Sistema di erogazione:** manuale
- **Altezza d'installazione consigliata:** 120/130 cm, dal pavimento alla parte inferiore del distributore
- **Peso netto:** 0,40 Kg

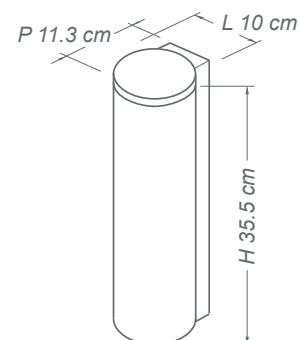

## GAMMA DI PRODUZIONE E VENDITA

### GAMMA STANDARD

#### BICCHIERI IN PLASTICA

PF-3052 : corpo superiore e riduttore ABS bianco, corpo inferiore e coperchio ABS grigio fumè

### IMBALLI/CONFEZIONI

#### IMBALLO SINGOLO

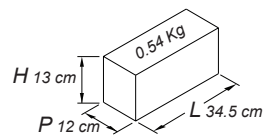

#### IMBALLO MULTIPLO

N° 20 DISPENSER

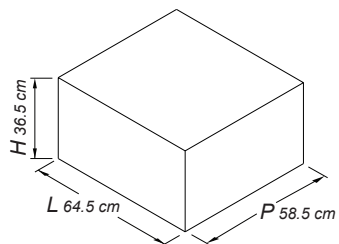

PESO LORDO 12 Kg  
PESO NETTO 8 Kg

#### PALLET IMBALLO MULTIPLO

12 SCATOLE MULTIPLE PER PALLET  
TOTALE 240 DISPENSER PER PALLET

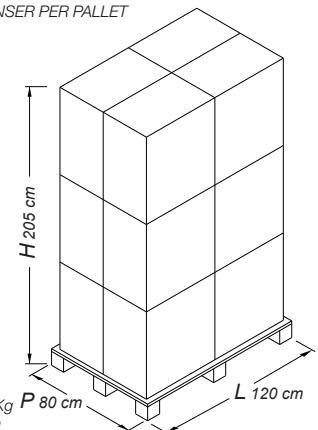

PESO LORDO 155 Kg  
PESO NETTO 96 Kg

### RICAMBI E ACCESSORI



1705302



10004



1705100